

# H.Stars Modular Chiller/Heat Pump



H.Stars (Guangzhou) Refrigerating Equipment Group Ltd.

- Air-cooled modular unit
- Air-cooled heat pump module
- Low ambient temperature air source (hot water) module
- Combined cooling, heat and power (trigeneration) module
- Special voltage module (optional)

- Water-cooled modular unit
- Water source heat pump module
- Low ambient temperature air source heat pump module
- Heat recovery module (optional)
- VSD module (optional)

## Model and specifications

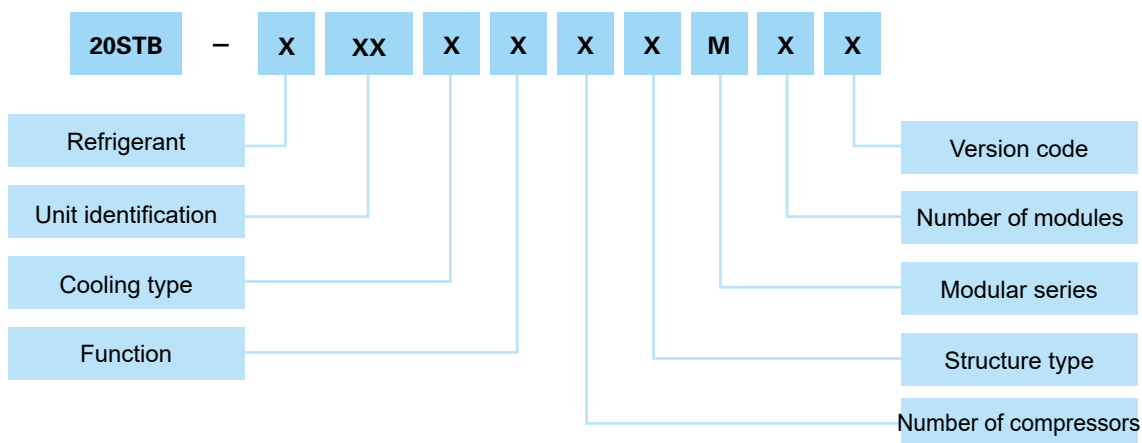

## Product profile

---

The modular unit adopts modular control technology, which combines multiple individual units into one combination for overall control. The combination operates with multiple slave units being controlled by a master unit; operation of multiple individual units can be centrally monitored and controlled on one control screen; and it is also possible that each unit operates independently.

### Smart operation

---

With each individual unit being independent with its own refrigerant and water circuits, the overall operating load of the modular unit can be controlled by adjusting the number of individual units working together; and failure of any one individual unit will not affect the normal operation of other individual units.

### Automatic control

---

Its microcomputer control system is easy to operate, with various protection and intelligent load control functions. The modular unit provides multiple protections for compressor, fan, water flow rate, high and low pressure of the refrigeration system, water temperature, and power supply, etc. And it is optional to use Siemens PLC controller to realize ModBus RTU, TCP or OPC communication.

### High-performance components

---

High-performance components The modular unit uses high-efficiency heat exchangers, low-energy fans, and brand-name compressors. Water system accessories such as pumps and filters can also be integrated according to customer requirements.

### Complete product range

---

There are 10 series of products available to select from to suit needs of different projects, including air-cooling modules, water-cooling modules, low ambient temperature air source modules, cold water modules, heat pump modules, and trigeneration modules.

### Non-standard products

---

Besides standard specifications, various non-standard units can also be available by customization.



## Product categories (Air-cooled series)

### Low ambient temperature module air source hot water

Low ambient temperature module air source hot water is designed to be used to provide heating in winter in extremely cold regions. One modular unit can consist of as many as 8 individual units. Individual unit's heating capacity range: 15kW-55kW; and ambient temperature range: -25 °C ~35 °C .

### Low ambient temperature module air source heat pump

Low ambient temperature module air source hot water is designed to be used to provide heating in winter and cooling in summer in cold northern regions. One modular unit can consist of as many as 8 individual units. Individual unit's heating capacity range: 15kW-55kW; cooling capacity range: 20kW-80kW; and ambient temperature range: -25 °C ~43°C .

### Air-cooled modular unit

Low ambient temperature module air source hot water is designed to be used to Air-cooled modular unit can provide cooling in summer without the need of cooling tower and machine room; and is suitable for projects that have insufficient water supply or lack machine room. One modular unit can consist of as many as 8 individual units. Individual unit's cooling capacity range: 60kW-160kW; chilled water temperature range: 5°C ~20°C ; ambient temperature range: 15°C ~43°C .

### Air-cooled module heat pump

Air-cooled module heat pump can provide cooling in summer and heating in winter without the need of cooling tower and machine room; and is suitable for projects that have insufficient water supply or lack machine room. One modular unit can consist of as many as 8 individual units. Individual unit's cooling capacity range: 60kW-160kW; heating capacity range: 70kW-170kW; chilled water temperature range: 5°C ~20°C ; hot water temperature range: 35°C ~50°C .

### Module combined cooling, heat and power (trigeneration)

Combined cooling, heat and power (trigeneration) module offers five functions to provide cooling, heating, hot water, hot and cold water, and heating and hot water; suitable for hotels, villas, hospitals, schools and other places that have cooling and heat demand. One modular unit can consist of as many as 8 individual units. Individual unit's cooling capacity range: 60kW-160kW; heating capacity range: 70kW-240kW; chilled water temperature range: 5°C ~20°C ; hot water temperature range: 35°C ~50°C ;

### System schematic of module air-cooled unit

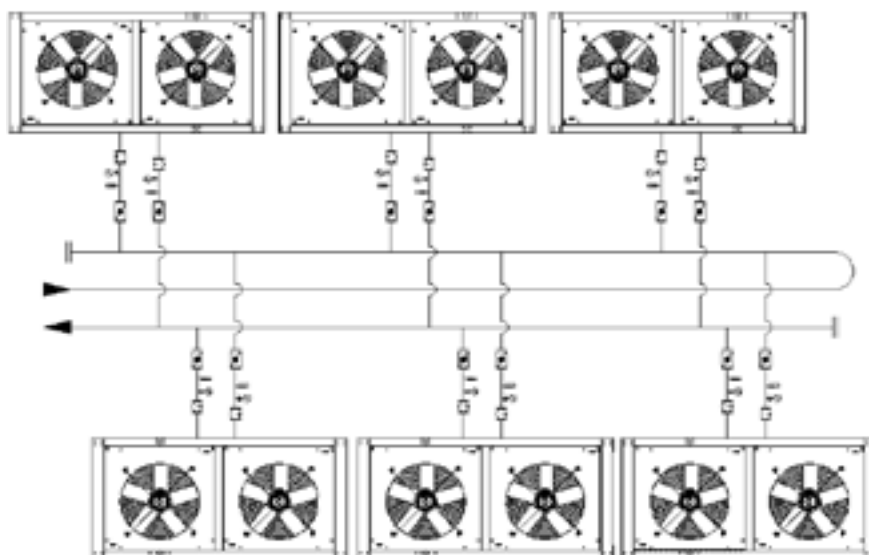

## Product categories (Water-cooled series)

### Water-cooled modular chiller

Water-cooled modular chiller, when completed with cooling tower, can provide cooling in summer; and it can consist of as many as 8 individual units. Cooling capacity range: 70kW–180kW; chilled water temperature range: 5°C ~20°C; cooled water temperature range: 15°C ~40°C;

### Water source module heat pump

Water source module heat pump, which can be used to provide cooling in summer and heating in winter, is high in energy efficiency and is suitable for projects that have sufficient water supply or access to ground water. One modular unit can consist of as many as 8 individual units. Cooling capacity range: 70kW~200kW; heating capacity range: 90kW-230kW; chilled water temperature range: 5°C ~20°C ; Max. hot water temperature: 50°C .

### Water-cooled module cooling system

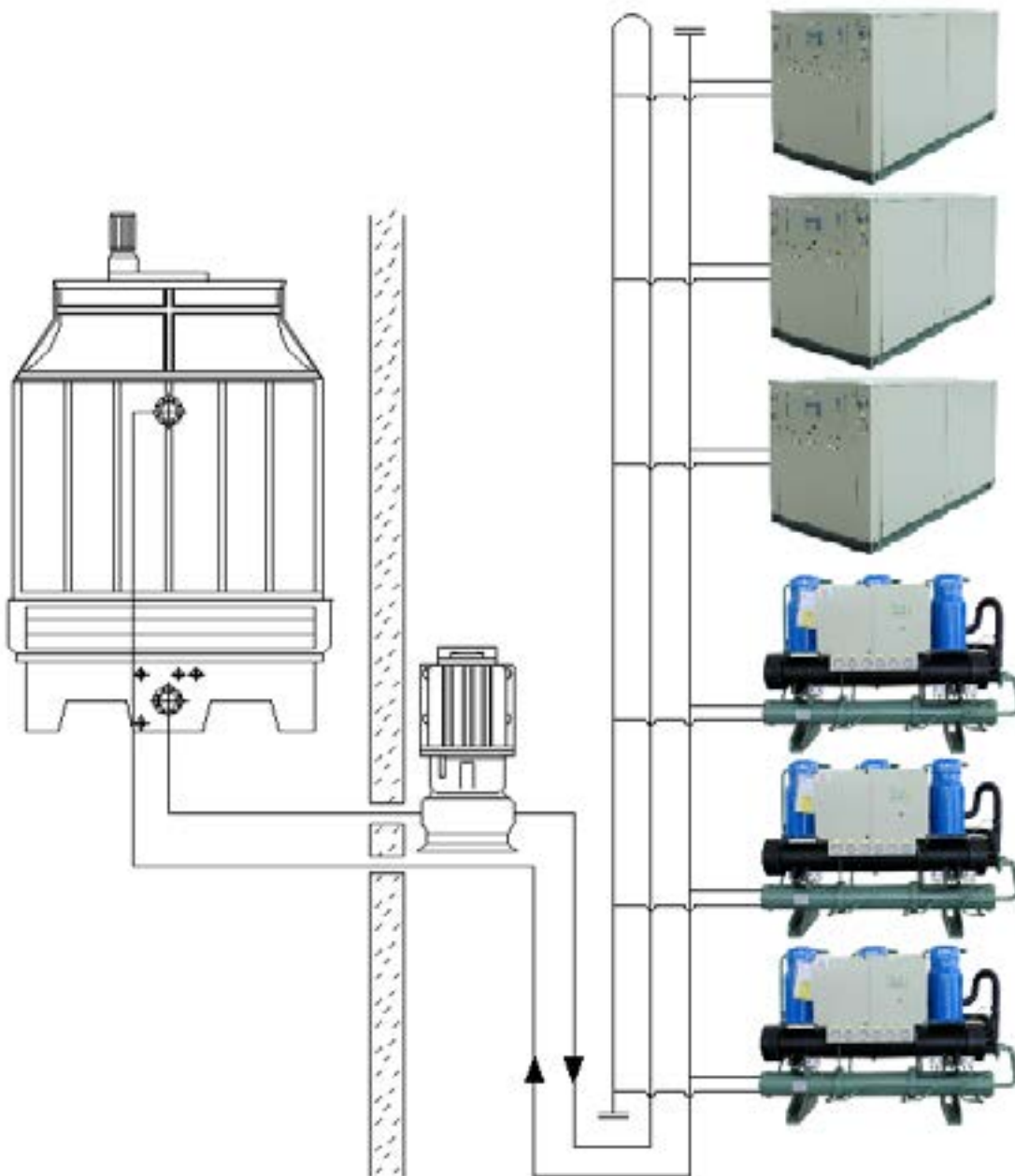

### Smart micro-processor control

---

The unit record during its operation the running time of compressors, so that the compressors can be started and stopped in a dynamical way in response to the start and stop of the unit, as well as to the loading and unloading of operating load, which helps to balance operation and wear among the compressors. Multiple levels of password protection are in place for the protection of parameters at all levels. Adjustable multiple timing: one-off timing, weekly timed switching on/off, weekly timing setting, and holiday setting.

### Flexible and easy combination

---

Up to 16 modules can be connected together, which offers wider range of capacity adjustment. Modular unit means easier and more flexible transportation and installation. It can be placed in various places of relatively small usable space, saving valuable building space. It also makes capacity expansion easier, and installment investment possible.

### Stable and reliable operation

---

There are multiple independent refrigerant systems in each module of the unit, therefore even when some of these systems give off alarm and stop operation, it will not affect the operation of other circuits, and the failure of a module will not affect the operation of other modules.

### High efficiency and energy saving

---

The unit's brand compressors and expansion valves, as well as self-produced high-efficiency heat exchangers, help to achieve high energy efficiency and low noise level, making the operation quieter and more efficient.

### Heat exchangers are available in a variety of materials

---

Heat exchanger is a main key component of the air conditioning unit, the manufacturing technology of which will have direct effects on product quality. As the only part of the unit that is in contact with outside air, heat exchange tubes are closely related to the service life of the unit. The thickness and material of heat exchange tubes are of critical importance, and customers may choose the right kind of tube according to air and water quality of the site of use.

### Complete range of functions

---

The modular unit series, offering for selection various types of units, including air-cooled modular chillers, air-source heat pump modular units, low ambient temperature hot water modular units, water-cooled modular chillers, and water-source heat pump modular units, stands to satisfy most application needs.

### Various additional upgrade options are available

---

VSD models, heat recovery models, low ambient temperature models, combined cooling, heat and power (trigeneration) models, special voltage models, and auxiliary electric heaters are available to meet the individual needs of different users.

### Centralized integrated control

---

Centralized operation control of multiple modules is based on the independent refrigerant circuits of each module, which realizes multi-stage energy regulation by controlling the start and stop of the compressors.



## Features

Operating information can be displayed on the control screen, such as temperatures of outlet water and return water, compressor's start and stop status, overload protection status, and pressure protection status of modules at all levels.

Based on the target water temperature of the main

pipe, the controller will automatically select and start the modules that have the shortest running time for loading adjustment; and will automatically skip a failed compressor and start the next one in the line. In the event of unloading, the module with the longest running time will be automatically selected and stopped for unloading adjustment.



## Parallel arrangement of multiple units

### Building Automation Connection (Optional)

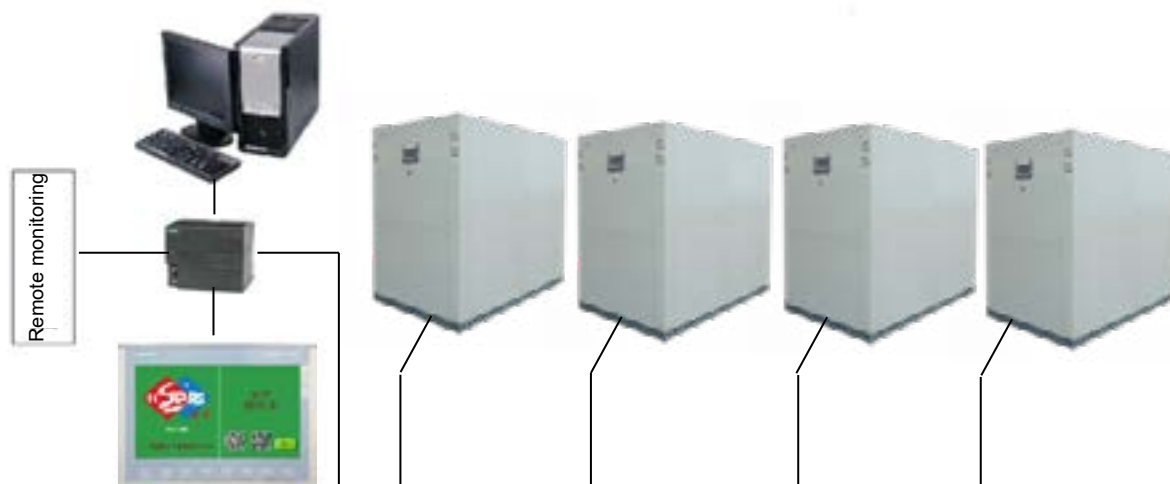

## Control functions

- Schedule control; users are allowed to freely set automatic switch time
- Automatic failure alarm and shutdown for the protection of the unit
- Enable connection with building BA system
- Multi-stage parameter setting
- Systems of independent operation control; intelligent identification and shutdown of failed systems.
- Support individual control and multi-unit parallel control
- Automatically balancing compressor run time
- Multi-stage capacity adjustment

# Module selection parameters (50Hz)

## Air-cooled modular unit technical parameters

Refrigerant: R410a Power Supply: 3 φ -380V-50Hz

Model	Nominal cooling capacity kW	Input Power kW	Number of compressor	Condenser			Evaporator				Operating sound dB(A)	Shipping weight kg
				Type	Air flow×1000m <sup>3</sup> /h	Power× Unit	Pipe connection inch	Water flow m <sup>3</sup> /h	Water Side MAX. Pressure MPa	Water pressure drop kPa		
20STB-V25ADM14	60	19	2	Copper tube with corrugated aluminum fins	29	1.2×2	2"	10	1	28	67	800
20STB-V30ADM14	78	24	2		40	2×2	2-1/2"	13	1	30	68	1600
20STB-V50ADM14	120	38	4		58	1.2×4	2-1/2"	21	1	33	69	2400
20STB-V60ADM14	156	48	4		80	2×4	2-1/2"	27	1	35	70	3200

Refrigerant: R22 Power Supply: 3 φ -380V-50Hz

Model	Nominal cooling capacity kW	Input Power kW	Number of compressor	Condenser			Evaporator				Operating sound dB(A)	Shipping weight kg
				Type	Air flow×1000m <sup>3</sup> /h	Power× Unit	Pipe connection inch	Water flow m <sup>3</sup> /h	Water Side MAX. Pressure MPa	Water pressure drop kPa		
20STB-25ADM14	64	17	2	Copper tube with corrugated aluminum fins	29	1.2 × 2	2"	11	1	28	67	800
20STB-30ADM14	80	24	2		40	2 × 2	2-1/2"	14	1	30	68	1600
20STB-50ADM14	128	34	4		58	1.2 × 4	2-1/2"	22	1	33	69	2400
20STB-60ADM14	160	48	4		80	2 × 4	2-1/2"	28	1	35	70	3200

Note:

- 1.Nominal cooling capacity reference: DB/WB ambient temperature 35°C /24°C , chilled water inlet and outlet temperature 12°C /7°C ; fouling factor 0.088 m<sup>2</sup> · °C /kW;
- 2.Chilled water temperature range: 5°C -20°C ;
- 3.Ambient temperature range: 15°C -43°C ;
- 4.Optional voltage: 220V, 380V, 400V, 415V, 440V, 460V
- 5.pedications and dimensions will be subject to improvement change without notice.

## Water-cooled modular unit technical parameters

Refrigerant: R410a Power Supply: 3 φ -380V-50Hz

Model	Nominal capacity kW	Input Power kW	Number of compressor	Condenser				Evaporator				Operating sound dB(A)	Shipping weight kg
				Pipe connection in	Water flow m <sup>3</sup> /h	Water Side MAX. Pressure Mpa	Water pressure drop kPa	Pipe connection in	Pipe connection in	Water Side MAX. Pressure Mpa	Water pressure drop kPa		
20STB-V25WDOM14	69	16	2	2"	15	1	56	2"	12	1	28	64	520
20STB-V30WDOM14	89	20	2	2-1/2"	19	1	58	2-1/2"	15	1	30	65	1000
20STB-V50WDOM14	138	32	4	3"	30	1	60	2-1/2"	24	1	33	66	1040
20STB-V60WDOM14	178	40	4	3"	38	1	61	2-1/2"	31	1	35	67	2000

Refrigerant: R22 Power Supply: 3 φ -380V-50Hz

Model	Nominal capacity kW	Input Power kW	Number of compressor	Condenser				Evaporator				Operating sound dB(A)	Shipping weight kg
				Pipe connection in	Water flow m <sup>3</sup> /h	Water Side MAX. Pressure Mpa	Water pressure drop kPa	Pipe connection in	Pipe connection in	Water Side MAX. Pressure Mpa	Water pressure drop kPa		
20STB-25WDOM14	70	14	2	2"	15	1	56	2"	12	1	28	64	520
20STB-30WDOM14	89	20	2	2-1/2"	19	1	58	2-1/2"	15	1	30	65	1000
20STB-50WDOM14	140	28	4	3"	30	1	60	2-1/2"	24	1	33	66	1040
20STB-60WDOM14	178	40	4	3"	38	1	61	2-1/2"	31	1	35	67	2000

Note:

- 1.Nominal cooling capacity reference: evaporator inlet and outlet water temperature 12°C /7°C , condenser inlet and outlet water temperature 30°C /35°C ; fouling factor 0.088 m<sup>2</sup> · °C /kW;
2. Chilled water temperature range: 5°C -20°C
3. Cooling water temperature range: 15°C -40°C ;
- 4.Optional voltage: 220V, 380V, 400V, 415V, 440V, 460V
5. Specifications and dimensions will be subject to improvement change without notice.



# Module selection parameters (50Hz)

## Air-cooled heat pump module technical parameters

Refrigerant: R410a Power Supply: 3 φ -380V-50Hz

Model	Nominal cooling		Nominal heating		Number of compressors	Condenser			Evaporator				Operating sound dB(A)	Shipping weight kg
	Capacity kW	Input Power kW	Capacity kW	Input Power kW		Type	Air flow×1000m <sup>3</sup> /h	Power×Unit	Pipe connection inch	Water flow m <sup>3</sup> /h	Water Side MAX. Pressure MPa	Water pressure drop kPa		
20STB-V25AHDM14	60	19	66	19	2	Copper tube with corrugated aluminum fins	29	1.2×2	2"	28	10	11	68	830
20STB-V30AHDM14	78	24	84	24	2		40	2×2	2-1/2"	30	13	14	69	1080
20STB-V50AHDM14	120	38	132	38	4		58	1.2×4	2-1/2"	33	21	23	70	1660
20STB-V60AHDM14	156	48	168	48	4		80	2×4	2-1/2"	35	27	29	71	2160

Refrigerant: R22 Power Supply: 3 φ -380V-50Hz

Model	Nominal cooling		Nominal heating		Number of compressors	Condenser			Evaporator				Operating sound dB(A)	Shipping weight kg
	Capacity kW	Input Power kW	Capacity kW	Input Power kW		Type	Air flow×1000m <sup>3</sup> /h	Power×Unit	Pipe connection inch	Water flow m <sup>3</sup> /h	Water Side MAX. Pressure MPa	Water pressure drop kPa		
20STB-25AHDM14	64	17	66	17	2	Copper tube with corrugated aluminum fins	29	1.2×2	2"	28	11	11	68	830
20STB-30AHDM14	80	24	85	24	2		40	2×2	2-1/2"	30	14	15	69	1080
20STB-50AHDM14	128	34	132	34	4		58	1.2×4	2-1/2"	33	22	23	70	1660
20STB-60AHDM14	160	48	170	48	4		80	2×4	2-1/2"	35	28	29	71	2160

Note:

- Nominal cooling capacity reference: DB/WB ambient temperature 35°C /24°C , chilled water inlet and outlet temperature 12°C /7°C ; fouling factor 0.088 m<sup>2</sup> ·°C /kW;
- Nominal heating capacity reference: DB/WB ambient temperature 7°C /6°C , hot water inlet and outlet temperature 40°C/45°C;
- Chilled water temperature range: 5°C -20°C ;
- Hot water temperature range: 35°C ~50°C ;
- Refrigeration ambient temperature range: 15°C ~43°C ; Heating ambient temperature range: -10°C ~43°C ;
- Optional voltage: 220V, 380V, 400V, 415V, 440V, 460V
- Specifications and dimensions will be subject to improvement change without notice.

## Water source heat pump module technical parameters

Refrigerant: R410a Power Supply: 3 φ -380V-50Hz

Model	Nominal cooling		Nominal heating		Number of compressors	Chilled water			Groundwater			Operating sound dB(A)	Shipping weight kg	Operating weight kg
	Capacity kW	Input Power kW	Capacity kW	Input Power kW		Pipe connection in	Water flow m <sup>3</sup> /h	Water pressure drop kPa	Pipe connection in	Water flow m <sup>3</sup> /h	Water pressure drop kPa			
20STB-V25WHDOM14	74	13	87	19	2	2"	13	28	2"	16	56	68	490	560
20STB-V30WHDOM14	96	18	111	25	2	2-1/2"	17	30	2-1/2"	21	58	69	580	650
20STB-V50WHDOM14	148	26	174	38	4	2-1/2"	25	33	3"	32	60	70	980	1120
20STB-V60WHDOM14	192	36	222	50	4	2-1/2"	33	35	3"	41	61	71	1160	1300

Refrigerant: R22 Power Supply: 3 φ -380V-50Hz

Model	Nominal cooling		Nominal heating		Number of compressors	Chilled water			Groundwater			Operating sound dB(A)	Shipping weight kg	Operating weight kg
	Capacity kW	Input Power kW	Capacity kW	Input Power kW		Pipe connection in	Water flow m <sup>3</sup> /h	Water pressure drop kPa	Pipe connection in	Water flow m <sup>3</sup> /h	Water pressure drop kPa			
20STB-25WHDOM14	74	13	88	17	2	2"	13	28	2"	16	56	68	490	560
20STB-30WHDOM14	93	18	114	24	2	2-1/2"	16	30	2-1/2"	20	58	69	580	650
20STB-50WHDOM14	148	26	176	34	4	2-1/2"	25	33	3"	32	60	70	980	1120
20STB-60WHDOM14	186	36	228	48	4	2-1/2"	32	35	3"	40	61	71	1160	1300

Note:

- Nominal cooling capacity reference: evaporator inlet and outlet water temperature 12°C /7°C , condenser inlet and outlet water temperature 30°C /35°C ; fouling factor 0.088 m<sup>2</sup> ·°C /kW;
- Chilled water temperature range: 5°C -20°C
- Cooling water temperature range: 15°C -40°C ;
- Optional voltage: 220V, 380V, 400V, 415V, 440V, 460V
- Specifications and dimensions will be subject to improvement change without notice.

# Module selection parameters (50Hz)

## Low ambient temperature modular air source heat pump parameters

Refrigerant: R22 Power Supply: 3 φ -380V-50Hz

Model	Nominal heating capacity kW	Input Power kW	Energy control %	Refrigerant charge kg	Evaporator			Condenser			Operating sound dB(A)	Shipping weight kg	Operating weight kg
					Structure Type	Air Volume m <sup>3</sup> /h	Power× Unit	Pipe connection in	Water flow m <sup>3</sup> /h	Water pressure drop kPa			
80HW-15CDSM14	14	4	0 100	5	Copper tube with hydrophilic corrugated aluminum fins	8100	0.52*1	1-1/4"	2	32	75	270	290
80HW-30CDSM14	24	6		6		8100	0.52*1		4	36	75	310	320
80HW-60CDDM14	49	13	0 50 100	12	Copper tube with hydrophilic corrugated aluminum fins	16200	1.04*2	1-1/2"	8	40	75	680	720
80HW-80CDDM14	55	14		15		25600	1.56*2		9	45	75	810	850

Note:

- Nominal heating capacity reference: ambient dry/wet bulb temperature -12°C /-14°C , air-conditioning inlet and outlet water temperature 50/55°C , water flow 0.172 m<sup>3</sup> /h\*kW.
- Ambient temperature range: -25°C ~43°C ;
- Optional voltage: 220V, 380V, 400V, 415V, 440V, 460V
- Specifications and dimensions will be subject to improvement change without notice.

## Low ambient temperature modular air source heat pump parameters

Refrigerant: R410a Power Supply: 3 φ -380V-50Hz

Model	Nominal cooling		Nominal heating		Energy control %	Refrigerant charge kg	Condenser			Evaporator			Operating sound dB(A)	Shipping weight kg	Operating weight kg
	Capacity kW	Input Power kW	Capacity kW	Input Power kW			Structure Type	Air Volume m <sup>3</sup> /h	Power× Unit	Pipe connection in	Water flow m <sup>3</sup> /h	Water pressure drop kPa			
20STB-V15CDHSM14	39	12	25	10	0 100	6	Copper tube with hydrophilic corrugated aluminum fins	16900	1.2*1	2"	7	45	65	650	710
20STB-V30CDHSM14	77	25	50	21	0 50 100	12		33800	1.2*2		13	55	70	1200	1290

制冷剂: R22 电源: 3 φ -380V-50Hz

Model	Nominal cooling		Nominal heating		Energy control %	Refrigerant charge kg	Condenser			Evaporator			Operating sound dB(A)	Shipping weight kg	Operating weight kg
	Capacity kW	Input Power kW	Capacity kW	Input Power kW			Structure Type	Air Volume m <sup>3</sup> /h	Power× Unit	Pipe connection in	Water flow m <sup>3</sup> /h	Water pressure drop kPa			
20STB-05CDHS4	20	4	14	4	0 100	3	Copper tube with hydrophilic corrugated aluminum fins	8500	0.52*1	1-1/4"	3	27	65	130	145
20STB-10CDHD4	40	9	27	7	0 50 100	6		17000	0.52*2		7	40	65	270	300
20STB-20CDHD4	72	15	49	13	10	10		23400	0.75*2	2"	12	50	70	750	810

Note:

- Nominal cooling capacity reference: DB/WB ambient temperature 35°C /24°C , chilled water inlet and outlet temperature 12°C /7°C ; fouling factor 0.088 m<sup>2</sup> ·°C /kW;
- Nominal heating capacity reference: DB/WB ambient temperature -12°C /-14°C , hot water inlet and outlet temperature 36°C/41°C;
- Chilled water temperature range: 5°C -20°C ;
- Hot water temperature range: 35°C ~50°C ;
- Refrigeration ambient temperature range: 20°C ~43°C ; Heating ambient temperature range: -25°C ~43°C ;
- Optional voltage: 220V, 380V, 400V, 415V, 440V, 460V
- Specifications and dimensions will be subject to improvement change without notice.

# Module selection parameters (50Hz)

## Modular Tri-function Combined Cooling and Heating parameters

Refrigerant: R410a Power Supply: 3 φ -380V-50Hz

Model	Nominal cooling		Nominal hot water		Nominal heating		Chilled water			hot water			Heat Exchanger		Axial Fan		Operating sound dB(A)	Shipping weight kg	Operating weight kg
	Capacity kW	Input Power kW	Capacity kW	Input Power kW	Heating capacity kW	Input Power kW	Pipe connection in	Water flow m <sup>3</sup> /h	Water pressure drop kPa	Pipe connection in	Water flow m <sup>3</sup> /h	Water pressure drop kPa	Water side heat exchanger	Air side heat exchanger	Air flow <sup>x</sup> 1000m <sup>3</sup> /h	Power <sup>x</sup> Unit			
30ST-V25AD4M14	60	19	86	24	66	19	2"	13	56	2"	15	28	shell and tube Copper tube with hydrophilic corrugated aluminum sheet		29	1.2 × 2	68	1030	1140
30ST-V30AD4M14	78	24	110	30	84	24	2-1/2"	17	58	2-1/2"	19	30			40	2.0 × 2	69	1280	1390
30ST-V50AD4M14	120	38	172	48	132	38	3"	26	60	2-1/2"	30	33			58	1.2 × 4	68	2060	2280
30ST-V60AD4M14	156	48	220	60	168	48	3"	34	61	2-1/2"	38	35				2.0 × 4	69	2560	2780

Refrigerant: R22 Power Supply: 3 φ -380V-50Hz

Model	Nominal cooling		Nominal hot water		Nominal heating		Chilled water			hot water			Heat Exchanger		Axial Fan		Operating sound dB(A)	Shipping weight kg	Operating weight kg
	Capacity kW	Input Power kW	Capacity kW	Input Power kW	Heating capacity kW	Input Power kW	Pipe connection in	Water flow m <sup>3</sup> /h	Water pressure drop kPa	Pipe connection in	Water flow m <sup>3</sup> /h	Water pressure drop kPa	Water side heat exchanger	Air side heat exchanger	Air flow <sup>x</sup> 1000m <sup>3</sup> /h	Power <sup>x</sup> Unit			
30ST-25AD4M14	64	17	92	22	66	17	2"	14	56	2"	15.824	28	shell and tube Copper tube with hydrophilic corrugated aluminum sheet		29	1.2 × 2	68	1030	1140
30ST-30AD4M14	80	24	118	30	85	24	2-1/2"	17	58	2-1/2"	20.296	30			40	2.0 × 2	69	1280	1390
30ST-50AD4M14	128	34	184	44	132	34	3"	28	60	2-1/2"	31.648	33			58	1.2 × 4	70	2060	2280
30ST-60AD4M14	160	48	236	60	170	48	3"	34	61	2-1/2"	40.592	35			80	2.0 × 4	71	2560	2780

Note

- Nominal refrigeration reference : ambient dry and wet bulb temperature 35°C/24°C, air conditioning chilled water inlet and outlet temperature 12°C/7°C;
- Nominal heating reference: ambient dry and wet bulb temperature 7°C/6°C, air-conditioning hot water inlet and outlet temperature 40°C/45°C;
- Nominal hot water reference: ambient dry and wet bulb temperature 20°C/15°C, domestic hot water inlet and outlet temperatures 50°C/55°C;
- Ambient temperature range: 15°C ~43°C ; heating ambient temperature range: -10°C ~43°C ; fouling factor 0.088 m<sup>2</sup> · °C /kW;
- Optional voltage: 220V, 380V, 400V, 415V, 440V, 460V
- Specifications and dimensions will be subject to improvement change without notice.

# Module selection parameters (60Hz)

## Air-cooled modular unit technical parameters

Refrigerant: R410a Power Supply: 3 φ -440V-60Hz

Model	Nominal cooling capacity kW	Input Power kW	Number of compressors	Condenser			Evaporator				Operating sound dB(A)	Shipping weight kg
				Type	Air flow×1000m <sup>3</sup> /h	Power× Unit	Pipe connection inch	Water flow m <sup>3</sup> /h	Water Side MAX. Pressure MPa	Water pressure drop kPa		
20STB-V25ADM14	72	23	2	Copper tube with corrugated aluminum fins	29	1.2×2	2"	12	1	28	67	800
20STB-V30ADM14	94	29	2		40	2×2	2-1/2"	16	1	30	68	1600
20STB-V50ADM14	144	46	4		58	1.2×4	2-1/2"	25	1	33	69	2400
20STB-V60ADM14	187	58	4		80	2×4	2-1/2"	32	1	35	70	3200

Refrigerant: R22 Power Supply: 3 φ -440V-60Hz

Model	Nominal cooling capacity kW	Input Power kW	Number of compressors	Condenser			Evaporator				Operating sound dB(A)	Shipping weight kg
				Type	Air flow×1000m <sup>3</sup> /h	Power× Unit	Pipe connection inch	Water flow m <sup>3</sup> /h	Water Side MAX. Pressure MPa	Water pressure drop kPa		
20STB-25ADM14	77	20	2	Copper tube with corrugated aluminum fins	29	1.2×2	2"	13	1	28	67	800
20STB-30ADM14	96	29	2		40	2×2	2-1/2"	17	1	30	68	1600
20STB-50ADM14	154	41	4		58	1.2×4	2-1/2"	26	1	33	69	2400
20STB-60ADM14	192	58	4		80	2×4	2-1/2"	33	1	35	70	3200

Note:

- 1.Nominal cooling capacity reference: DB/WB ambient temperature 35°C /24°C , chilled water inlet and outlet temperature 12°C /7°C ; fouling factor 0.088 m<sup>2</sup> · °C /kW;
- 2.Chilled water temperature range: 5°C -20°C ;
- 3.Ambient temperature range: 15°C -43°C ;
- 4.Optional voltage: 220V, 380V, 400V, 415V, 440V, 460V
- 5.pedications and dimensions will be subject to improvement change without notice.

## Water-cooled modular unit technical parameters

Refrigerant: R410a Power Supply: 3 φ -440V-60Hz

Model	Nominal capacity kW	Input Power kW	Number of compressors	Condenser				Evaporator				Operating sound dB(A)	Shipping weight kg
				Pipe connection in	Water flow m <sup>3</sup> /h	Water Side MAX. Pressure Mpa	Water pressure drop kPa	Pipe connection in	Pipe connection in	Water Side MAX. Pressure Mpa	Water pressure drop kPa		
20STB-V25WDOM14	83	19	2	2"	18	1	56	2"	14	1	28	64	520
20STB-V30WDOM14	107	24	2	2-1/2"	23	1	58	2-1/2"	18	1	30	65	1000
20STB-V50WDOM14	166	38	4	3"	36	1	60	2-1/2"	29	1	33	66	1040
20STB-V60WDOM14	214	48	4	3"	46	1	61	2-1/2"	37	1	35	67	2000

Refrigerant: R22 Power Supply: 3 φ -440V-60Hz

Model	Nominal capacity kW	Input Power kW	Number of compressors	Condenser				Evaporator				Operating sound dB(A)	Shipping weight kg
				Pipe connection in	Water flow m <sup>3</sup> /h	Water Side MAX. Pressure Mpa	Water pressure drop kPa	Pipe connection in	Pipe connection in	Water Side MAX. Pressure Mpa	Water pressure drop kPa		
20STB-25WDOM14	84	17	2	2"	18	1	56	2"	14	1	28	64	520
20STB-30WDOM14	107	24	2	2-1/2"	23	1	58	2-1/2"	18	1	30	65	1000
20STB-50WDOM14	168	34	4	3"	36	1	60	2-1/2"	29	1	33	66	1040
20STB-60WDOM14	214	48	4	3"	46	1	61	2-1/2"	37	1	35	67	2000

Note:

- 1.Nominal cooling capacity reference: evaporator inlet and outlet water temperature 12°C /7°C , condenser inlet and outlet water temperature 30°C /35°C ; fouling factor 0.088 m<sup>2</sup> · °C /kW;
2. Chilled water temperature range: 5°C -20°C
3. Cooling water temperature range: 15°C -40°C ;
- 4.Optional voltage: 220V, 380V, 400V, 415V, 440V, 460V
5. Specifications and dimensions will be subject to improvement change without notice.

# Module selection parameters (60Hz)

## Air-cooled heat pump module technical parameters

Refrigerant: R410a Power Supply: 3 φ -440V-60Hz

Model	Nominal cooling		Nominal heating		Number of compressors	Condenser			Evaporator				Operating sound dB(A)	Shipping weight kg
	Capacity kW	Input Power kW	Capacity kW	Input Power kW		Type	Air flow×1000m <sup>3</sup> /h	Power×Unit	Pipe connection inch	Water flow m <sup>3</sup> /h	Water Side MAX. Pressure MPa	Water pressure drop kPa		
20STB-V25AHDM14	72	23	79	23	2	Copper tube with corrugated aluminum fins	29	1.2×2	2"	28	12	14	68	830
20STB-V30AHDM14	94	29	101	29	2		40	2×2	2-1/2"	30	16	17	69	1080
20STB-V50AHDM14	144	46	158	46	4		58	1.2×4	2-1/2"	33	25	27	70	1660
20STB-V60AHDM14	187	58	202	58	4		80	2×4	2-1/2"	35	32	35	71	2160

Refrigerant: R22 Power Supply: 3 φ -440V-60Hz

Model	Nominal cooling		Nominal heating		Number of compressors	Condenser			Evaporator				Operating sound dB(A)	Shipping weight kg
	Capacity kW	Input Power kW	Capacity kW	Input Power kW		Type	Air flow×1000m <sup>3</sup> /h	Power×Unit	Pipe connection inch	Water flow m <sup>3</sup> /h	Water Side MAX. Pressure MPa	Water pressure drop kPa		
20STB-25AHDM14	77	20	79	20	2	Copper tube with corrugated aluminum fins	29	1.2×2	2"	28	13	14	68	830
20STB-30AHDM14	96	29	102	29	2		40	2×2	2-1/2"	30	17	18	69	1080
20STB-50AHDM14	154	41	158	41	4		58	1.2×4	2-1/2"	33	26	27	70	1660
20STB-60AHDM14	192	58	204	58	4		80	2×4	2-1/2"	35	33	35	71	2160

Note:

1. Nominal cooling capacity reference: DB/WB ambient temperature 35°C /24°C , chilled water inlet and outlet temperature 12°C /7°C ; fouling factor 0.088 m<sup>2</sup> ·°C /kW;
2. Nominal heating capacity reference: DB/WB ambient temperature 7°C /6°C , hot water inlet and outlet temperature 40°C/45°C;
3. Chilled water temperature range: 5°C -20°C ;
4. Hot water temperature range: 35°C ~50°C ;
5. Refrigeration ambient temperature range: 15°C ~43°C ; Heating ambient temperature range: -10°C ~43°C ;
6. Optional voltage: 220V, 380V, 400V, 415V, 440V, 460V
7. Specifications and dimensions will be subject to improvement change without notice.

## Water source heat pump module technical parameters

Refrigerant: R410a Power Supply: 3 φ -440V-60Hz

Model	Nominal cooling		Nominal heating		Number of compressors	Chilled water			Groundwater			Operating sound dB(A)	Shipping weight kg	Operating weight kg
	Capacity kW	Input Power kW	Capacity kW	Input Power kW		Pipe connection in	Water flow m <sup>3</sup> /h	Water pressure drop kPa	Pipe connection in	Water flow m <sup>3</sup> /h	Water pressure drop kPa			
20STB-V25WHDOM14	89	16	104	23	2	2"	15	28	2"	19	56	68	490	560
20STB-V30WHDOM14	115	22	133	30	2	2-1/2"	20	30	2-1/2"	25	58	69	580	650
20STB-V50WHDOM14	178	31	209	46	4	2-1/2"	31	33	3"	38	60	70	980	1120
20STB-V60WHDOM14	230	43	266	60	4	2-1/2"	40	35	3"	49	61	71	1160	1300

Refrigerant: R22 Power Supply: 3 φ -440V-60Hz

Model	Nominal cooling		Nominal heating		Number of compressors	Chilled water			Groundwater			Operating sound dB(A)	Shipping weight kg	Operating weight kg
	Capacity kW	Input Power kW	Capacity kW	Input Power kW		Pipe connection in	Water flow m <sup>3</sup> /h	Water pressure drop kPa	Pipe connection in	Water flow m <sup>3</sup> /h	Water pressure drop kPa			
20STB-25WHDOM14	89	16	106	20	2	2"	15	28	2"	19	56	68	490	560
20STB-30WHDOM14	112	22	137	29	2	2-1/2"	19	30	2-1/2"	24	58	69	580	650
20STB-50WHDOM14	178	31	211	41	4	2-1/2"	31	33	3"	38	60	70	980	1120
20STB-60WHDOM14	223	43	274	58	4	2-1/2"	38	35	3"	48	61	71	1160	1300

Note:

1. Nominal cooling capacity reference: evaporator inlet and outlet water temperature 12°C /7°C , condenser inlet and outlet water temperature 30°C /35°C ; fouling factor 0.088 m<sup>2</sup> ·°C /kW;
2. Chilled water temperature range: 5°C -20°C
3. Cooling water temperature range: 15°C -40°C ;
4. Optional voltage: 220V, 380V, 400V, 415V, 440V, 460V
5. Specifications and dimensions will be subject to improvement change without notice.

# Module selection parameters (60Hz)

## Low ambient temperature modular air source heat pump parameters

Refrigerant: R22 Power Supply: 3 φ -440V-60Hz

Model	Nominal heating capacity kW	Input Power kW	Energy control %	Refrigerant charge kg	Evaporator			Condenser			Operating sound dB(A)	Shipping weight kg	Operating weight kg
					Structure Type	Air Volume m <sup>3</sup> /h	Power× Unit	Pipe connection in	Water flow m <sup>3</sup> /h	Water pressure drop kPa			
80HW-15CDSM14	17	5	0 100	5	Copper tube with hydrophilic corrugated aluminum fins	8100	0.52*1	1-1/4"	3	32	75	270	290
80HW-30CDSM14	29	7		6		8100	0.52*1		5	36	75	310	320
80HW-60CDDM14	58	14	0 50 100	12		16200	1.04*2	1-1/2"	9	40	75	680	720
80HW-80CDDM14	66	17		15		25600	1.56*2		11	45	75	810	850

Note:

- Nominal heating capacity reference: ambient dry/wet bulb temperature -12°C /-14°C , air-conditioning inlet and outlet water temperature 50/55°C , water flow 0.172 m<sup>3</sup> /h\*kW.
- Ambient temperature range: -25°C ~43°C ;
- Optional voltage: 220V, 380V, 400V, 415V, 440V, 460V
- Specifications and dimensions will be subject to improvement change without notice.

## Low ambient temperature modular air source heat pump parameters

Refrigerant: R410a Power Supply: 3 φ -440V-60Hz

Model	Nominal cooling		Nominal heating		Energy control %	Refrigerant charge kg	Condenser			Evaporator			Operating sound dB(A)	Shipping weight kg	Operating weight kg
	Capacity kW	Input Power kW	Capacity kW	Input Power kW			Structure Type	Air Volume m <sup>3</sup> /h	Power× Unit	Pipe connection in	Water flow m <sup>3</sup> /h	Water pressure drop kPa			
20STB-V15CDHSM14	47	14	30	12	0 100	6	Copper tube with hydrophilic corrugated aluminum fins	16900	1.2*1	2"	8	45	65	650	710
20STB-V30CDHSM14	94	28	60	24	0 50 100	12		33800	1.2*2		16	55	70	1200	1290

制冷剂: R22 Power Supply: 3 φ -440V-60Hz

Model	Nominal cooling		Nominal heating		Energy control %	Refrigerant charge kg	Condenser			Evaporator			Operating sound dB(A)	Shipping weight kg	Operating weight kg
	Capacity kW	Input Power kW	Capacity kW	Input Power kW			Structure Type	Air Volume m <sup>3</sup> /h	Power× Unit	Pipe connection in	Water flow m <sup>3</sup> /h	Water pressure drop kPa			
20STB-05CDHS4	24	5	17	5	0 100	3	Copper tube with hydrophilic corrugated aluminum fins	8500	0.52*1	1-1/4"	4	27	65	130	145
20STB-10CDHD4	48	10	34	10	0 50 100	6		17000	0.52*2		8	40	65	270	300
20STB-20CDHD4	86	18	59	16	10	10		23400	0.75*2	2"	15	50	70	750	810

Note:

- Nominal cooling capacity reference: DB/WB ambient temperature 35°C /24°C , chilled water inlet and outlet temperature 12°C /7°C ; fouling factor 0.088 m<sup>2</sup> ·°C /kW;
- Nominal heating capacity reference: DB/WB ambient temperature -12°C /-14°C , hot water inlet and outlet temperature 36°C/41°C ;
- Chilled water temperature range: 5°C -20°C ;
- Hot water temperature range: 35°C ~50°C ;
- Refrigeration ambient temperature range: 20°C ~43°C ; Heating ambient temperature range: -25°C ~43°C ;
- Optional voltage: 220V, 380V, 400V, 415V, 440V, 460V
- Specifications and dimensions will be subject to improvement change without notice.



# Module selection parameters (60Hz)

## Modular Tri-function Combined Cooling and Heating parameters

Refrigerant: R410a Power Supply: 3 φ -440V-60Hz

Model	Nominal cooling		Nominal hot water		Nominal heating		Chilled water			Hot water			Heat Exchanger		Axial Fan		Operating sound dB(A)	Shipping weight kg	Operating weight kg
	Capacity kW	Input Power kW	Capacity kW	Input Power kW	Heating capacity kW	Input Power kW	Pipe connection in	Water flow m <sup>3</sup> /h	Water pressure drop kPa	Pipe connection in	Water flow m <sup>3</sup> /h	Water pressure drop kPa	Water side heat exchanger	Air side heat exchanger	Air flow×1000m <sup>3</sup> /h	Power× Unit			
30ST-V25AD4M14	72	23	103	29	79	23	2"	15	56	2"	18	28	shell and tube Copper tube with hydrophilic corrugated aluminum sheet		29	1.2×2	68	1030	1140
30ST-V30AD4M14	94	29	132	36	101	29	2-1/2"	20	58	2-1/2"	23	30			40	2.0×2	69	1280	1390
30ST-V50AD4M14	144	46	206	58	158	46	3"	31	60	2-1/2"	35	33			58	1.2×4	68	2060	2280
30ST-V60AD4M14	187	58	264	72	202	58	3"	40	61	2-1/2"	45	35			80	2.0×4	69	2560	2780

Refrigerant: R22 Power Supply: 3 φ -440V-60Hz

Model	Nominal cooling		Nominal hot water		Nominal heating		Chilled water			Hot water			Heat Exchanger		Axial Fan		Operating sound dB(A)	Shipping weight kg	Operating weight kg
	Capacity kW	Input Power kW	Capacity kW	Input Power kW	Heating capacity kW	Input Power kW	Pipe connection in	Water flow m <sup>3</sup> /h	Water pressure drop kPa	Pipe connection in	Water flow m <sup>3</sup> /h	Water pressure drop kPa	Water side heat exchanger	Air side heat exchanger	Air flow×1000m <sup>3</sup> /h	Power× Unit			
30ST-25AD4M14	77	20	110	26	79	20	2"	17	56	2"	19	28	shell and tube Copper tube with hydrophilic corrugated aluminum sheet		29	1.2×2	68	1030	1140
30ST-30AD4M14	96	29	142	36	102	29	2-1/2"	21	58	2-1/2"	24	30			40	2.0×2	69	1280	1390
30ST-50AD4M14	154	41	221	53	158	41	3"	33	60	2-1/2"	38	33			58	1.2×4	70	2060	2280
30ST-60AD4M14	192	58	283	72	204	58	3"	41	61	2-1/2"	49	35			80	2.0×4	71	2560	2780

Note

- Nominal refrigeration reference : ambient dry and wet bulb temperature 35°C/24°C, air conditioning chilled water inlet and outlet temperature 12°C/7°C;
- Nominal heating reference: ambient dry and wet bulb temperature 7°C/6°C, air-conditioning hot water inlet and outlet temperature 40°C/45°C;
- Nominal hot water reference: ambient dry and wet bulb temperature 20°C/15°C, domestic hot water inlet and outlet temperatures 50°C/55°C;
- Ambient temperature range: 15°C ~43°C ; heating ambient temperature range: -10°C ~43°C ; fouling factor 0.088 m<sup>2</sup> ·°C /kW;
- Optional voltage: 220V, 380V, 400V, 415V, 440V, 460V
- Specifications and dimensions will be subject to improvement change without notice.

# Correction coefficient

## Air-cooled module chiller

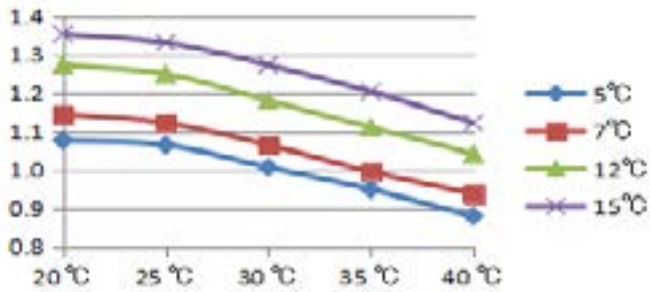

Correction coefficient of water

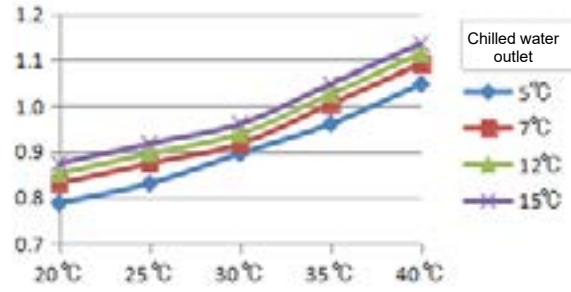

Correction coefficient of water cooled input power

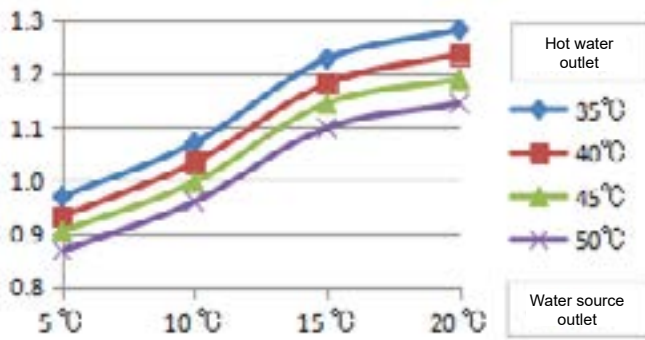

Correction coefficient of water source heating capacity

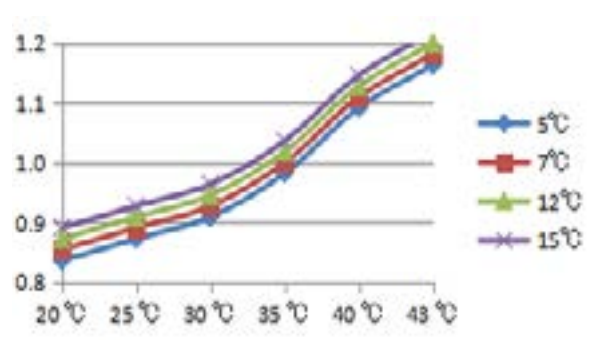

Correction coefficient of water source heating input power

## Water-cooled module chiller

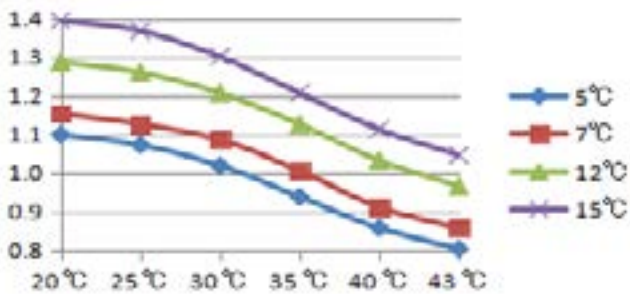

Correction coefficient of air cooled cooling capacity

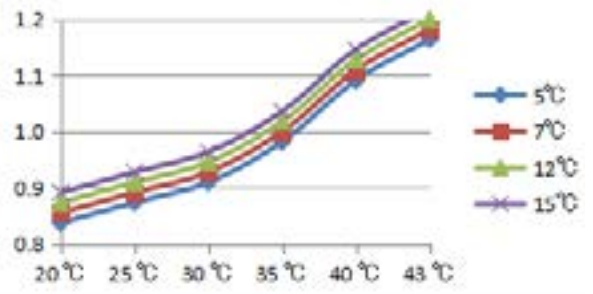

Correction coefficient of air cooled input power

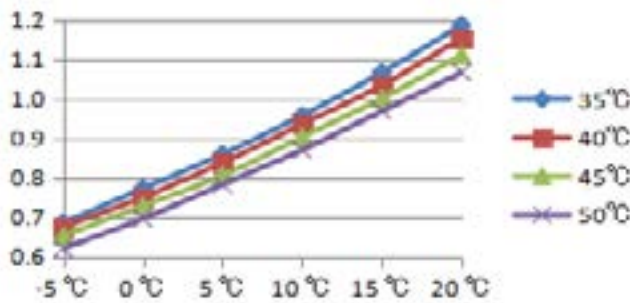

Correction coefficient of air cooled heating capacity

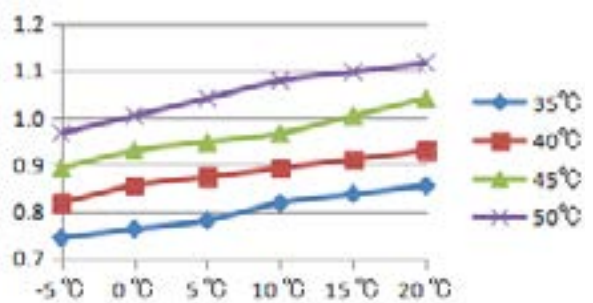

Correction coefficient of air cooled heating input power

## Heat recovery module (optional)

65°C

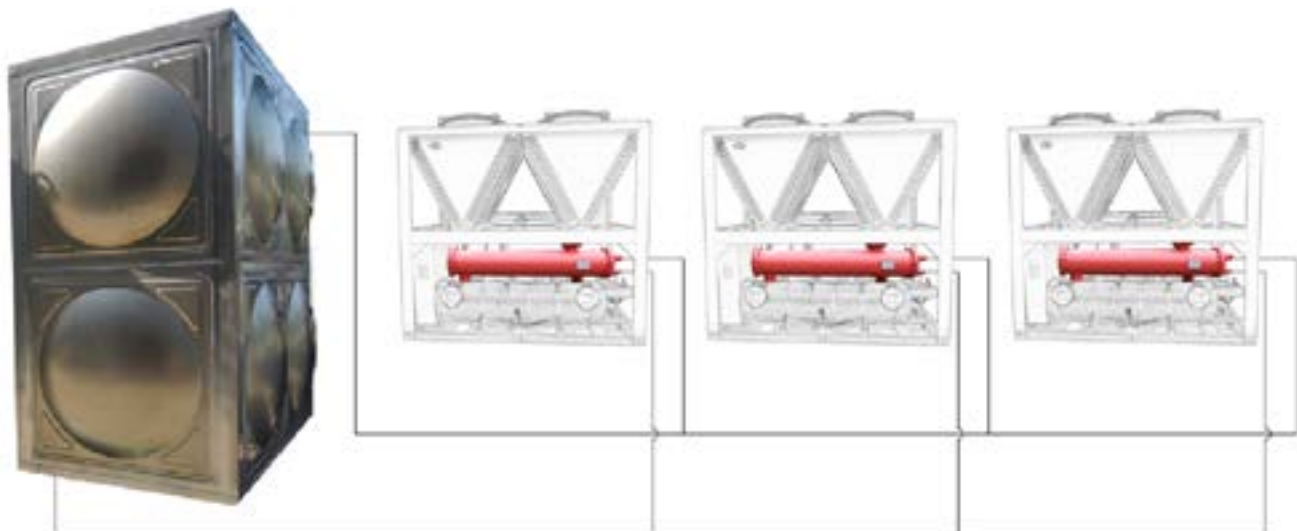

### Introduction to heat recovery

Heat recovery is a technology that applies a recovery device to partially or completely recover the heat energy generated by the unit during the cooling process, and uses it to provide customers with free hot water of 45~65°C . It is suitable for use in large public institutions and places such as hotels, hospitals, and schools. One machine for two purposes, eco-friendly and energy saving.

Having been in the research and application of heat recovery technology for a long time, H.Stars Group has accumulated extensive experience in heat recycling, and has its own national patent of heat recovery. Application of the technology in projects provides customers with free hot water, saving a lot of hot water costs. It reduces thermal pollution to the environment caused by condensation heat, and at the same time lowers the operating costs, as well as the noise of the cooling tower.

### Introduction to heat recovery

Model NO.	30% Heat recovery rate		100% Heat recovery rate	
	Heat recovery model	Heating Capacity (kW)	Heat recovery model	Heating Capacity (kW)
20STB-25ADM14	UHR008A	25	UHR025A	75
20STB-30ADM14	UHR010A	30	UHR030A	90
20STB-50ADM14	UHR016B	50	UHR050B	150
20STB-60ADM14	UHR020B	60	UHR060B	180
20STB-25WDOM14	UHR008A	25	UHR025A	75
20STB-30WDOM14	UHR010A	30	UHR030A	90
20STB-50WDOM14	UHR016B	50	UHR050B	150
20STB-60WDOM14	UHR020B	60	UHR060B	180



### Introduction to VSD system

VSD unit is made by adding a variable-frequency drive to an existing unit, which can realize operation of the compressor at different frequencies. This technology greatly improves the energy efficiency of the unit during partial load operation, making it highly efficient in terms of both coefficient of performance (COP) and integrated part load value (IPLV).

### Low startup current

VSD screw units offer soft start function to reduce the impact of starting current; the frequency converter comes with a DC reactor that can minimize harmonic interference; and there is also an optional low harmonic filter which, under the input power of the frequency converter, is in line with IEEE- 519 specification for harmonic distortion, and equipped with functions of harmonic filter over-temperature protection and capacitor switching.

### Precise temperature control

The water temperature can be controlled with an accuracy tolerance of  $\pm 0.3$  degrees, meeting the requirements of high-precision temperature control.

### Stable and reliable

VSD hot water unit regulates the output load by controlling the speed of the motor speed, which realizes real stepless capacity adjustment; meanwhile, the reliability of the compressor is also improved. An independent air duct is dedicated to cool the variable-frequency drive to ensure its low-temperature and more reliable operation.

## Auxiliary electric heater (optional)

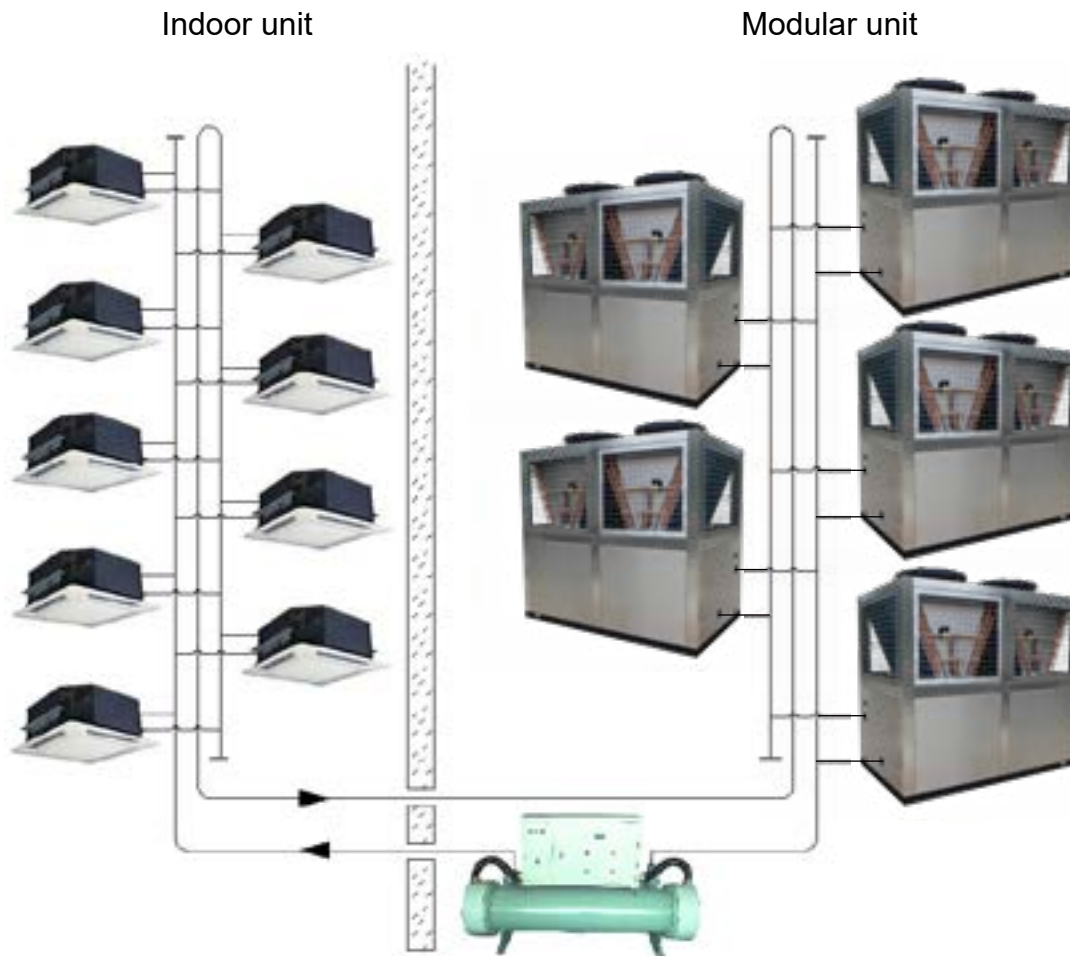

### Parameters of auxiliary electric heaters

Unit model	Auxiliary electric heating kW
20STB-(V)25ADM14	25
20STB-(V)30ADM14	30
20STB-(V)50ADM14	50
20STB-(V)60ADM14	60
20STB-(V)25WDOM14	25
20STB-(V)30WDOM14	30
20STB-(V)50WDOM14	50
20STB-(V)60WDOM14	60

### Use instructions

In the event of outdoor heating in regions of extremely low temperature, the evaporation temperature of the air source heat pump unit must be very low, entailing the compressor working at a high compression ratio, which will inevitably lead to decrease of the volumetric efficiency and indicated thermal efficiency of the compressor. As a result, the heating capacity and the coefficient of performance of the heat pump are reduced. A preferred way to solve the problem is to use auxiliary heat source equipment, and auxiliary electric heater is an ideal choice.



## Dimensional drawing of single module (air-cooled/air-source)

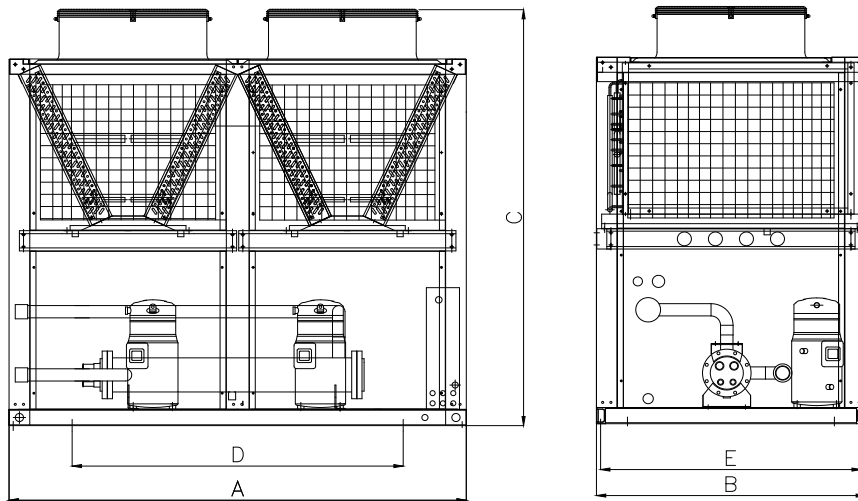

MODEL	A	B	C	D	E
20STB-(V)25ADM14/20STB-(V)25AHDM14	2200	1040	1950	1200	1000
20STB-(V)30ADM14/20STB-(V)30AHDM14	2200	1300	2050	1200	1260
20STB-(V)50ADM14/20STB-(V)50AHDM14	2200	2080	1950	1200	2040
20STB-(V)60ADM14/20STB-(V)60AHDM14	2600	2210	2050	1600	2170

## Single unit basic installation dimension drawing

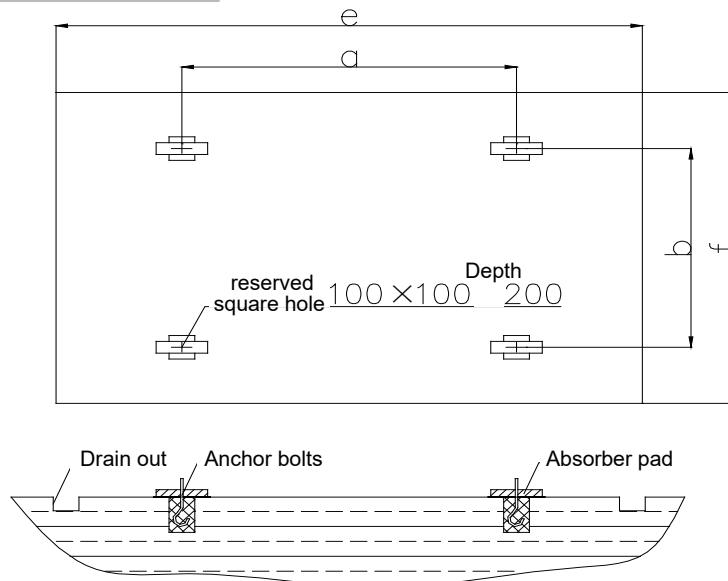

MODEL	A	B	C	D	E
20STB-(V)25ADM14/20STB-(V)25AHDM14	1200	1000	2200	1040	400
20STB-(V)30ADM14/20STB-(V)30AHDM14	1200	1260	2200	1300	400
20STB-(V)50ADM14/20STB-(V)50AHDM14	1200	2040	2200	2080	1000
20STB-(V)60ADM14/20STB-(V)60AHDM14	1600	2170	2600	2210	1000



## Dimensional drawing of single module (air-cooled/air-source)

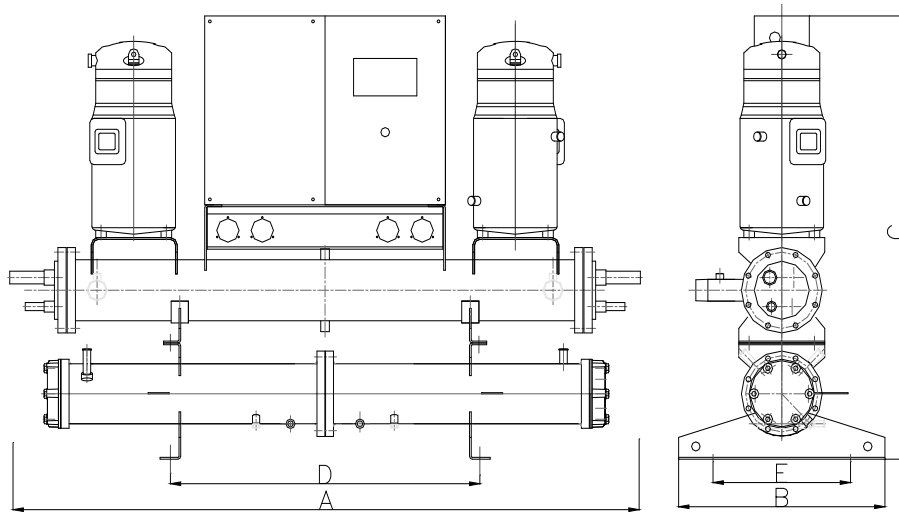

MODEL	A	B	C	D	E
20STB-(V)25WDOM14/20STB-(V)25WHDOM14	1900	600	1220	900	400
20STB-(V)30WDOM14/20STB-(V)30WHDOM14	2200	600	1430	1200	400
20STB-(V)50WDOM14/20STB-(V)50WHDOM14	1900	1200	1220	900	1000
20STB-(V)60WDOM14/20STB-(V)60WHDOM14	2200	1200	1430	1200	1000

## Single unit basic installation dimension drawing

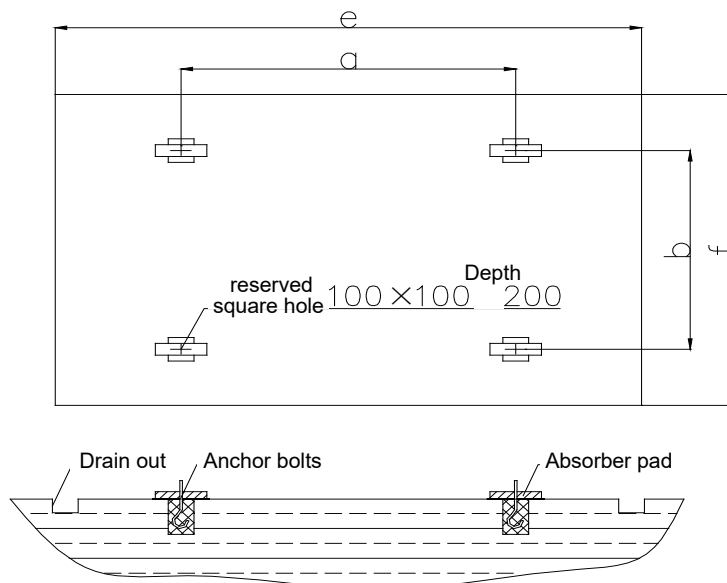

MODEL	A	B	C	D	E
20STB-(V)25WDOM14/20STB-(V)25WHDOM14	900	400	2000	600	400
20STB-(V)30WDOM14/20STB-(V)30WHDOM14	1200	400	2300	600	400
20STB-(V)50WDOM14/20STB-(V)50WHDOM14	900	1000	2000	1200	1000
20STB-(V)60WDOM14/20STB-(V)60WHDOM14	1200	1000	2300	1200	1000

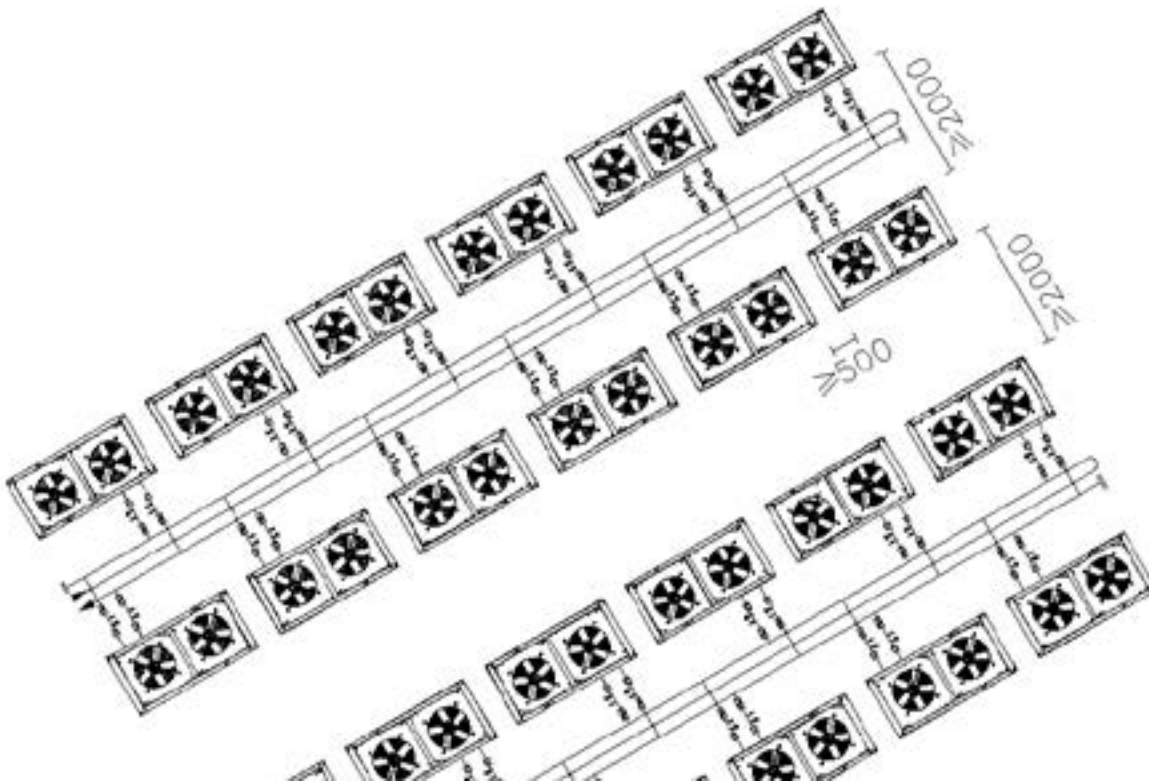

※please consult the manufacturer or its sales representative for more installation information.

### Dimension drawing of individual unit installation with base

- Installation of the unit can connect up to 16 modules as may be allowed by the actual length or width of the installation site.
- A space not less than 500mm must be reserved on the connection side of a module, two parallel rows of unit must be kept apart at least 2000mm, and the air outlet must have a clearance space of not less than 1500mm, and thereby to ensure adequate air circulation, as well as access for system maintenance.
- When multiple modules are combined, it is recommended that a dual water supply-return system be used to ensure balanced water pressure of each unit and consequently high operation efficiency.
- The highest point of the water system must be reserved for installation of the exhaust valve and the expansion tank.
- The unit must be installed on a concrete foundation or a trough frame; placing directly on the floor shall be avoided to prevent corrosion damage.
- The circulation water pump of the system must be selected in accordance with pump head and the demand load of the unit, and with a margin of 30%.
- Each module must be equipped with manual shut-off valve and soft joint.
- Standard configuration of water circuit system: water flow switch, filter, pressure gauge and pressure bypass valve.
- The unit is designed to have upwards exhaust airflow; therefore a space of  $\geq 1500\text{mm}$  must be reserved.
- When installed on the roof, a shock absorber must be provided to prevent resonance and noise from the operation of the unit.

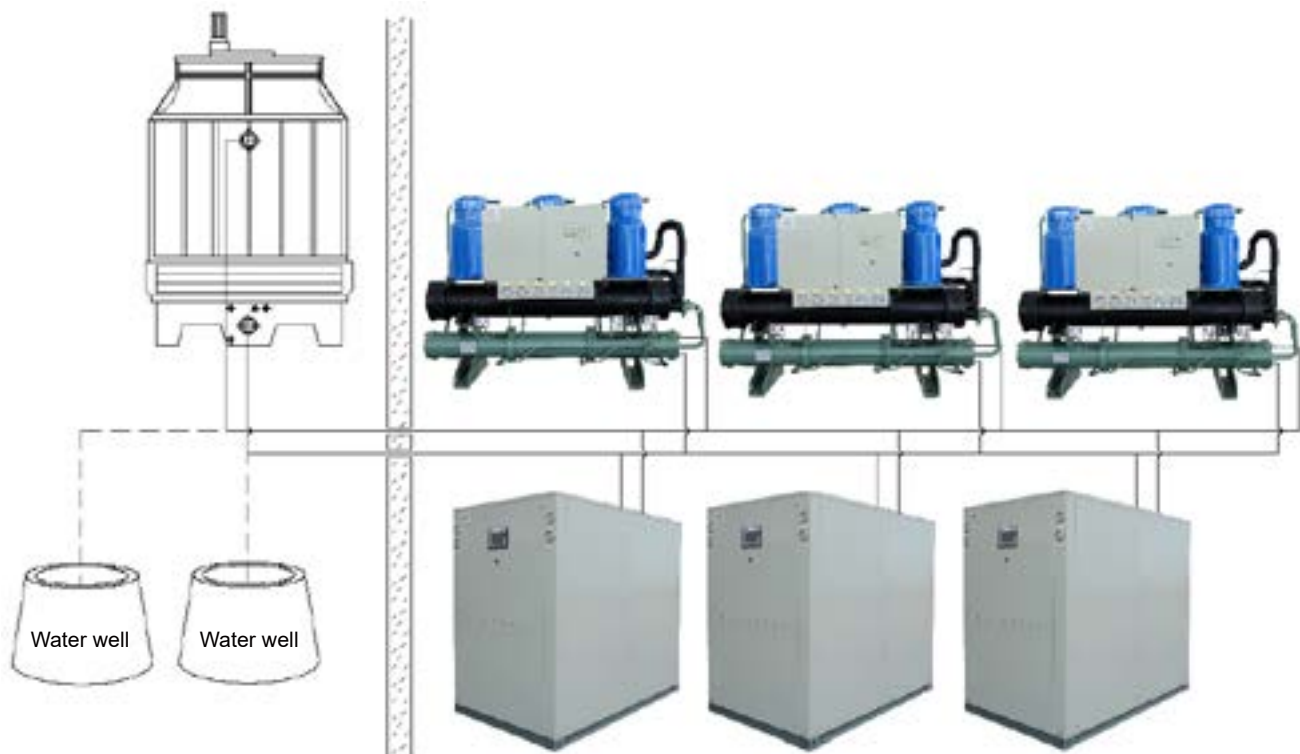

### Applications of water-cooled module chiller

- The main function of the water-cooled module chiller is to cool collectively one or more groups of module through the central water tower. This simple and flexible system has low investment cost, and is suitable for places where operation is required at different times.
- The most salient advantage of the water-cooled module chiller is its high performance in energy

saving; its operating cost is about 40% lower than an air-cooling module

- The system enables simple and flexible use. Customers can choose the number of units to be turned on according to load demands; with supply being regulated by demand, the system is simpler, more flexible, and energy-saving than systems of larger size.

### Applications of water source module heat pump

- The water source module heat pump derives energy from groundwater or heat containing sewage to perform such functions as cooling, heating, and domestic hot water provision. With a cooling coefficient of performance (COP) as high as 5.0, it is efficient and environmentally friendly, serving multiple purpose with one unit.

- To use water source heat pump there must be stable water source, and the water temperature must be maintained at 8°C or above.

- Modular water source heat pumps are generally used in small and medium-sized projects for their advantages of low investment cost, simplicity and flexibility, multi-function and multi-purpose, environmental protection and energy saving.



**H.Stars Group**

H.Stars (Guangzhou) Refrigerating Equipment Group Ltd., established in 1992, in Economic & Technological Development Zone of Guangzhou, China, composed of 8 subsidiaries to provide one-stop solution to HVAC customers, specializing in R&D, production, design and installation. As the company grows, H.Stars group expands its business globally and has sold to 53 different countries. H.Stars Group is awarded with "New and High Technology Enterprise in Guangzhou" and has become the training base of many universities both in China and abroad via technology cooperation.

H.Stars Group supplies an extensive line of Commercial and Industrial Energy Saving HVAC products including: Air Cooled Chiller, Water Cooled Chiller, Industrial Chiller, Centrifugal Chiller, Magnetic oil free centrifugal chiller, Multifunction Chiller, Hot Water Unit, Heat Recovery Unit, Heat Pump Unit, Condensing Unit, Glycol Chiller, Shell and Tube Heat Exchanger, Air Handling Unit, Fan Coil Unit, Cooling Tower, etc. all type of HVAC products.

H.Stars Group has been dedicated in quality and innovation and is technically strong in commercial and industrial application as a HVAC manufacturer. Apart from obtaining plenty of energy-saving product patents, H.Stars Group has achieved CE certifications for Pressure Vessel and standard chillers, BR1, ASME, ISO9001:2000, ISO14001:2004 and other certifications.

A good reputation of H.Stars Group has been built and delivers a full HVAC service to customers worldwide. Our products are widely applied in industries for cooling of Laser generators, Welding electrodes, Cutting machines, Electric spark machines, Extrusion process, Hydraulic System, Electroplating, Ultrasonic Cleaning, Ion Plating film, Electronic facility, Electrical appliance components, Compressed Gas Dehumidification, Dairy and Beverage Cooling processing, Pharmaceutical and Biological products, Medical equipment, Glass Coating, Tempered Glass and Cultivation Sea Food.

H.Stars Group will continue to develop energy saving and environmental friendly equipment to create "The Efficiency Planet" as our obligation. By focusing on customers' needs and wants in order to contribute more our potentials, from now on, H.Stars Group will hand in hand with you to be a shining star in the foreseeable future.

## **H.Stars (Guangzhou) Refrigerating Equipment Group Ltd.**

Address: No.1 Guoyuan 4th Road, Guangzhou Economic & Technological Development Zone, HuangPu District, Guangzhou, China Zip Code 510530

Email: [sales@hstars.com.cn](mailto:sales@hstars.com.cn)

Tel: +862062266755 ext. 886

Fax: +862082266081

Website: [www.hstarschiller.com](http://www.hstarschiller.com)

Twitter: [twitter.com/HStarsGroup](https://twitter.com/HStarsGroup)

Facebook: [www.facebook.com/Hstarsgroup](https://www.facebook.com/Hstarsgroup)

LinkedIn: [www.linkedin.com/company/hstarsgroup](https://www.linkedin.com/company/hstarsgroup)

Instagram: [www.instagram.com/hstars\\_chiller\\_maker](https://www.instagram.com/hstars_chiller_maker)

